

# MBA 1100L Plus



- High-quality high-density polyethylene HDPE
- Rugged
- Robust design & construction
- Compliant with EN840 superseding all other global standards

## General Specifications

High-density polyethylene makes the product highly resistant to atmospheric conditions and gives it great stability against fluctuations in temperature. Ideal for different types of waste collection; paper and cardboard, glass, plastics & packaging, organic matter etc. Integrated handles in the body and lid for easy handling.

The four-wheeled units can optionally be fitted with steering systems and brakes on all wheels where needed. Product Approval Certificate awarded by TUV Product Service GmbH Germany in accordance with European Standard EN840

Hot Stamping insignia or logo available to lid and body.

Can be equipped with a range of accessories providing real solutions to every requirement:

- Pedal-operated lid opening
- Reflective strips
- Wheel directional lock [for towing]
- Drawbar for towing

The **1100L MBAplus** is manufactured using stabilised colours against the combined effects of water and UV rays. The quality materials used in production give the dimensions a much tighter tolerance, impact resistance. Incorporating maximum resistance to weight loading, easy to handle & clean, drain plug in body, resistant to effects of weather and acid or alkaline solutions, fungi, bacteria, washing detergents etc. It is produced for most Australasian lifting systems and adapts perfectly to different types of selective collection: glass, paper, solid waste and co-mingled recyclables, etc.

The **1100L MBAplus** model is equipped with four solid rubber tyred wheels with steel hubs on swivel castor brackets, two of which incorporate individual foot brakes (brakes on the four wheels, directional locks, etc. as options). Plastic points most susceptible to damage have been strengthened.

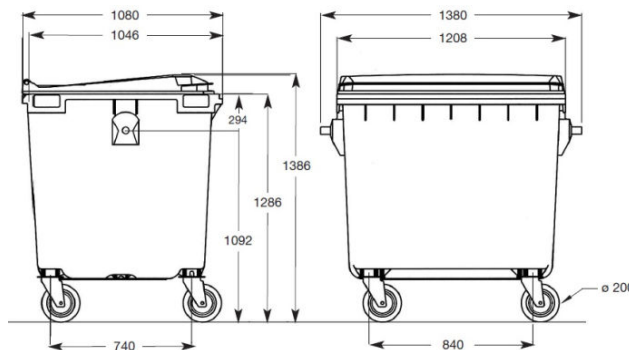

## COLOUR CHOICE

Nature Green	Red	Aspek Blue	Grey	Orange
Yellow-Medical	Black	Century Blue	Dark Green	Burgundy



Robust Moulded Handle



Custom made steel pocket Also Available



Solid tyre & foot brake

## MOBILE BINS AUSTRALIA PTY LTD

Victorian Office C/-  
31A Halsey Rd, Airport West  
Victoria Australia 3042  
Phone: 03 9335 1771  
Fax: 03 9338 2833  
Email: [info@mobilebins.com.au](mailto:info@mobilebins.com.au)