

MBA 12 Volt AC Electro Hydraulic Bin Lifter

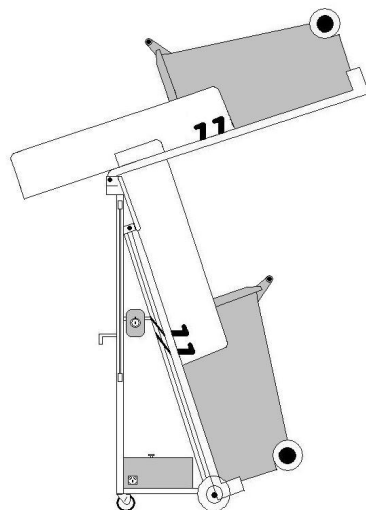

Main Features 12 Volt DC:

- Gel Filled Low Maintenance Battery:
- Built In Single Phase Charger:
- Safety Warning Light:
- Standard 240 Litre MGB's:
- 120 Litre MGB's Upon Request
- Large Chute For Controlled Product Flow:
- 2 x 250 Large Solid Wheels:
- 2 x 125 Directional Locking Castors:
- Weather Proof Power Pack:
- Weather Proof Battery Pack:
- Lockable Battery Box:
- Push Button Up And Down:
- Controlled 12 Second Raise And Decent:
- Forty To Sixty Cycles Between Charges:
- Easily Attached To Bulk Skips:
- Easy Attachment of MGB's:
- Easy Release Of MGB's:
- Customized to Individual Containers:
- Customised to Individual Tipping Heights:

Above is a 12 Volt DC powered bin lifter with a tipping height of 1,830mm and capacity of 150kg. Strongarm Manufacturing & Sales P/L is an Australian owned and operated company.

All of our products are designed by a Mechanical Engineer and manufactured in Australia using Australian Materials and labour.

Please note that the above photo is for illustration purposes only.
New models may vary from this illustration photograph.

MOBILE BINS AUSTRALIA PTY LTD

Victorian Office C/-
31A Halsey Rd, Airport West
Victoria Australia 3042
Phone: 03 9335 1771
Fax: 03 9338 2833
Email: info@mobilebins.com.au