

MBA 6.0m³

Steel Front Lift Bins



SFLB 6.0 Front Lift Bin

Certified stackable space saving bins fitted with fork pockets, painted or galvanized finish, manufactured to comply strictly with Australian and WHS Standards. SRB Bins are suitable for storing & transporting all types of materials. Sureline will customise the design & manufacture of these bins to meet your specific requirements.

Optional Features:

- 3 Surface Finishes:
 - Galvanised.
 - Marine Paint Spec.
 - Tuffcoat Paint Spec.
- Patented Gravity Lid Lock System.
- Whisper Pockets.
- Double Skin Plastic Lids.
- Steering Rails.
- Drain Holes.
- Fork Lift Pockets.
- Wheels: Dia 150mm Nylon over Cast Steel, with Brakes & Swivels, Quick Install & Disconnect.
- GPS Secure Housing.



PRODUCT SPECIFICATIONS:

Type	Capacity (m ³)	W.L.L* (kg)	Length (mm)	Width (mm)	Height (mm)
SRB 6.0	6.0	2500	2036	1943	1605

* W.L.L = Working Load

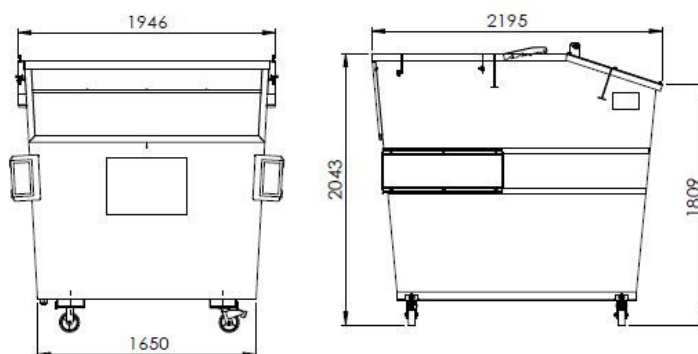

MOBILE BINS AUSTRALIA PTY LTD

Victorian Office C/-
31A Halsey Rd, Airport West
Victoria Australia 3042
Phone: 03 9335 1771
Fax: 03 9338 2833
Email: info@mobilebins.com.au